

Destructive Testing of Wood Plastic Composite

ZUZANA MITALOVÁ^{1*}, JULIÁNA LITECKÁ², DUŠAN MITAL¹,
 MARTA HARNIČÁROVÁ^{3,4}, JAN VALÍČEK^{3,4}, CRISTINA STEFANA MIRON-BORZAN^{5*},
 MARIAN BORZAN⁵

¹Faculty of Manufacturing Technologies of Technical University of Košice with a seat in Prešov, Slovakia

²Faculty of Humanities and Natural Science, Ul. 17. Novembra 1, 08016 Prešov, Slovakia

³Institute of Technology and Business in České Budějovice, Faculty of Technology, Department of Mechanical Engineering, Okružní 10, 370 01 České Budějovice, Czech Republic

⁴Slovak University of Agriculture in Nitra, Faculty of Engineering, Tr. A. Hlinku 2, Nitra, 949 76, Slovakia

⁵Technical University of Cluj-Napoca, Faculty of Machine Building, Department of Manufacturing Engineering, 28 Memorandumului Str., 400114, Cluj, Romania

Abstract: *The paper deals with destructive testing of “new” group of material - Wood Plastic Composite (in short WPC). WPC emerging from a fusion of two different kinds of components - thermoplastics matrix and natural reinforcement (fibres or flour). Natural fibres offer several advantages - they are renewable, inexpensive, low-density, good isolate a sound and low cost. These components are mixed under the influence of high temperature and then pressed to make various shapes. This material contains cracks localized on the interface between the wood and plastic. These cracks occurred due to inhomogeneity of WPC and affected mechanical properties of final WPC product. The testing of mechanical properties (tensile test and bending test) were determinate in VUHZ Dobra (Ostrava) - following the ISO standards. Significant differences between mechanical properties after testing were caused by non-perfect encapsulation between components and non-homogeneity of materials.*

Keywords: *Wood Plastic Composite, mechanical properties, non-homogeneous material*

1. Introduction

Wood Plastic Composites (WPC) present a new group of materials emerging from a fusion of two homogeneous materials – a polymer matrix and cellulose fibres with additives (lubricants, coupling agents, flame retardants, fungicides, light stabilizers, fillers) in a specific relation. These components are mixed under the influence of high temperature and then pressed to make various WPC products. WPC can be produced in a variety of colours, sizes, shapes and different textures of the surface. This composite material provides many advantages (Figure 1). A presence of wood in the matrix increases strength and stiffness. They are environmentally friendly because they are produced from agricultural waste and recycled plastics (for example PVC bottles and carpets) [1].

Wood Plastic Composite (WPC)		
high	PRICE	low
low	FLEXURAL MODULUS	high
high	THERMAL CONDUCTIVITY	low
low	CORROSION/ FUNGI RESISTANCE	high
difficult	COLOUR DESIGN	simple
difficult	MACHINING	simple
low	FIRE RESISTANCE	high

↓
IDEAL MATERIAL

Figure 1. Properties of Wood Plastic Composite

Nowadays, WPCs displace traditional materials such as wood (or rare wood – seak? and teak), steel, plastics and cement materials (Figure 2).

*email:borzan_cristina@ymail.com



Figure 2. Application of WPC material (UPM ProFi) for shingle cladding (World Expo 2010, Shanghai) [2]

WPCs are used for the production of cladding, window frames, park benches, fences, boat (marine) flooring, outdoor playgrounds, and many other applications (pallets or tool handles) [3]. The scope of WPC materials application has been gradually expanding. Therefore, the mechanical properties of WPC materials are “tailor-made” for a given application (in relation to a number of basic components/additives and a manufacturing process). Many published studies have addressed the relation between the mechanical/physical properties of the composite and the length of used fibres, the volume and type of individual components (additives) and their effects on the mechanical properties. The publication of English and Falk provides a general overview of the factors that affect the final properties of WPC products. Some studies (Wechsler and Hiziroglu) have shown that compatibility between fibres and matrix can be improved by selecting suitable coupling agents (for example MAPP – Maleic Anhydride Polypropylene). On the other hand, this coupling agent increases tensile strength (from 21.09 MPa to 35.60 MPa) [4]. The structure of wood is important, too – different wood species have different anatomical structures (Maldas et al.) [5]. Study Stark and Rowland evaluated how wood flour and fibre characteristics influence the mechanical properties of polypropylene composites (results support the use of higher aspect ratio wood fibres and coupling agents for increasing the strength of WPC composites) [6]. Aspect ratio (length/width of particle) is very important parameter for WPC production (Rowell et al./Bouafif et al.) [7]. Adhikary et al. investigated mechanical properties and microstructure of WPC made using a recycled or virgin plastic matrix (HDPE). Bending and tensile properties of profile on recycled HDPE were equivalent to those based on virgin HDPE [8]. Effect of mixing ratio of components is evaluated in the study of Chen et al. Researchers increased the contents of wood to 75 % and obtained excellent dimensional stability [9]. Study of Vinayagamorthy investigated chemically treated natural fibre (with alkali, peroxide, and benzoyl chloride) as reinforcements. The results confirmed that benzoylation improved the tensile/compressive, and impact strengths of the composite. Peroxide treatment has improved the flexural strength and improved the elongation of the composite during tension, flexure, and compression tests [10]. The most commonly used methods to produce WPC product are [11-12] extrusion (for linear profile) and injection moulding (for 3D parts) and calendering (for flooring). These processes follow the same basic steps: melting, shaping and cooling. Study of Migneault et al. investigated the first two methods (extrusion and injection moulding) and effect on the structure and properties of WPC. The technology of injection moulding resulted in better composite physical and mechanical properties than the extrusion process, but higher density was obtained with the extrusion process [13]. Therefore, many published studies have addressed the relation between the mechanical/physical properties of the composite and the length of used fibres [14, 15], the volume and type of individual components (additives) and their effects on the mechanical properties [16, 17], the effects of manufacturing process parameters on final properties of the composite [18], and the range of current and future applications [19]. The presented paper discusses the experimental assessment of the selected

mechanical properties of one type of WPC profile that has been pushed through commercially (used in the decking industry).

2. Materials and methods

The examined material (Figure 3) is a wood-filled plastic with a component ratio: 30% HDPE matrix and 70% wooden particles.

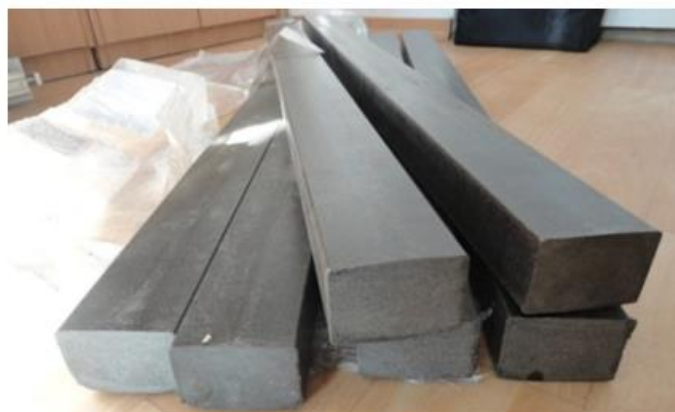

Figure 3. Examined material – Wood Plastic Composite (extruded profile)

The size of the wooden particles ranges from 420 μm to roughly 2 mm; during the profile production, the direction of wooden particles copies the substance flow. The material contains some cracks located in the wood/plastic contact area (isolated micro-cracks are present in wooden particles) [20-21] (Figure 4).



Figure 4. Microcracks localized on the contact between wood particles and plastic matrix [14]

The mechanical properties of the samples were determined in the VUHZ Ostrava – Dobra laboratories. The tensile testing was performed following the ISO 6892 standard (universal testing machine TIRA Test 2300 (Figure 5)). Three-point bending test was performed following the ISO 178 standard. The tested samples were taken in the direction of the extrusion axis from the middle section of the profile (Figure 6). There were five samples made for each testing method (shape of testing pieces samples (Figure 7)).



Figure 5. TIRA Test 2300 – universal testing machine for the tensile test (following the ISO 6892)

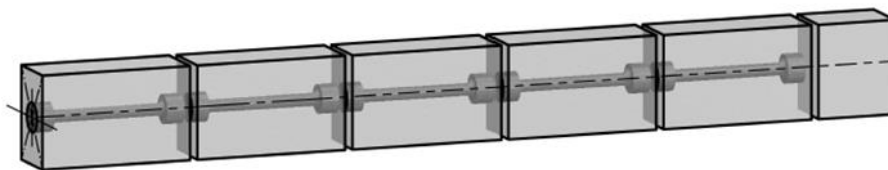

Figure 6. Test samples localization on the extruded WPC profile (for the tensile test)

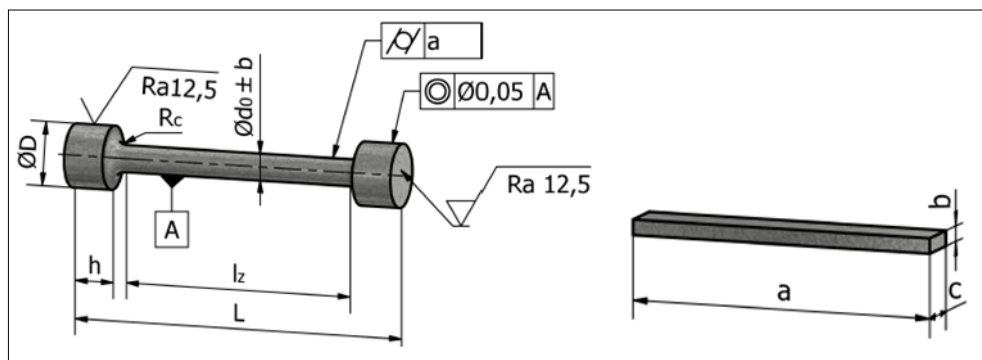

Figure 7. Test sample: left side – test sample for the tensile test ($d_o = 8.0 \pm 0.05$ mm, $D = 19$ mm, $h = 12.0$ mm, $l_z = 70$ mm, $L = 100$ mm, $R_c = 4$ mm); right side – test sample for the bending test ($a = 80 \pm 1.0$ mm, $b = 4 \pm 1.0$ mm, $c = 10 \pm 0.5$ mm)

3. Results and discussions

The tensile testing was carried out at the room temperature following the ISO standard, at a speed of $0.015 \text{ mm}\cdot\text{s}^{-1}$. Due to the high notch sensitivity of the material, the tensibility is not determined using a conventional procedure (measuring the distance between the fracture and the gauge marks). Instead, an alternative method was used - determining the extension from the load diagram at the moment of fracture. In order to determine deformation work, a load diagram was used. Yield strength could not be determined properly since there are no conventional values of offset yield strength to establish the insignificant yield strength.

Figure 8 and 9 show the tensile testing results. Table 1 shows the actual values. Tensile strength values show significant differences. They range from 15-24 MPa - that is a difference of 9.0 MPa between the individual samples. The minimum elongation value was detected in Sample 1 (2.8 %); the maximum elongation was detected in Sample 5 (5.1 %). Contraction values range from 0.4-2.0 %. Sample 5 snapped under a tension of 200 N, most likely due to a defect. The three-point bending test was performed following the ISO 178 standard. The experiment was conducted at the load speed of $0.08 \text{ mm}\cdot\text{s}^{-1}$. To determine deformation work, we used a load diagram.

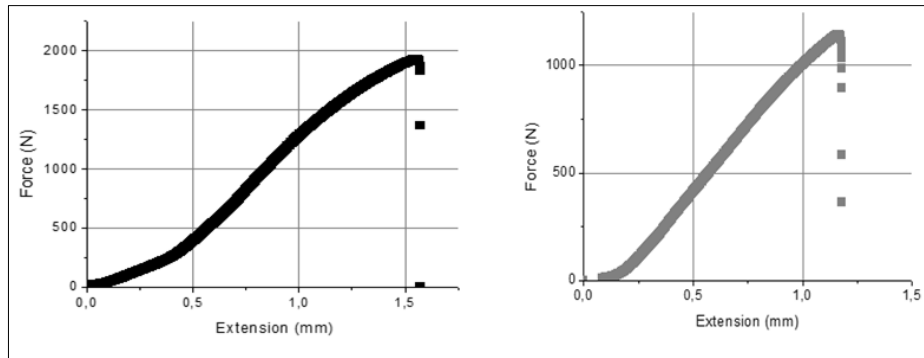

Figure 8. Load diagram of the tensile test: left side – for sample 1, right side – for sample 2

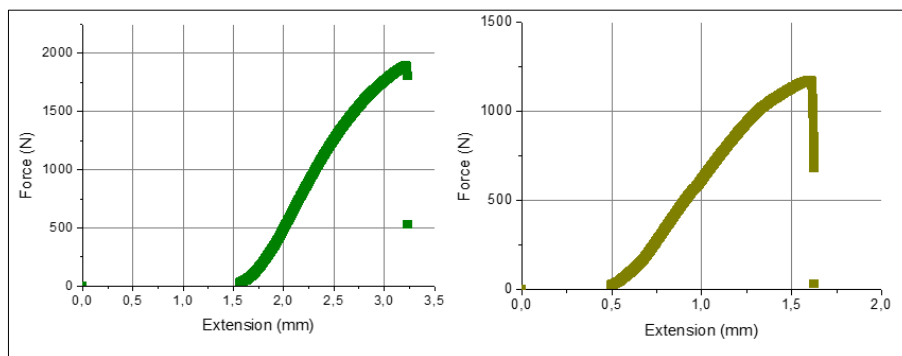

Figure 9. Load diagram of the tensile test: left side – for sample 3, right side – for sample 4

For the given dependence of force F on elongation Δl in Figure 8 and Figure 9, it is necessary to process the data in statistical-mathematical way for further identification, namely, in our case by regression equations including the closeness of agreement.

For the dependence in Figure 8 on the left the polynomial equation (1) with the correlation coefficient $R^2 = 0,985$ is applied:

$$F = 148.6 \cdot \Delta l^2 + 1192.5 \cdot \Delta l - 146.2 \quad (1)$$

For the dependence in Figure 8 on the right the polynomial equation (2) with the correlation coefficient $R^2 = 0,994$ is applied:

$$F = -52.2 \cdot \Delta l^2 + 1217.8 \cdot \Delta l - 173.4 \quad (2)$$

For the dependence in Figure 9 on the left the polynomial equation (3) with the correlation coefficient $R^2 = 0,988$ is applied:

$$F = -197.5 \cdot \Delta l^2 + 2206.2 \cdot \Delta l - 3076.8 \quad (3)$$

For the dependence in Figure 9 on the right the polynomial equation (4) with the correlation coefficient $R^2 = 0,984$ is applied:

$$F = -397.2 \cdot \Delta l^2 + 1980.9 \cdot \Delta l - 956.5 \quad (4)$$

Table 1. Results of tensile test.

Sample No.	Tensile strength [MPa]	Elongation [%]	Contraction [%]	Deformation work [mJ]
1	24	2.8	2.0	20.4
2	15	2.9	0.4	12.4
3	24	3.4	0.8	24.1
4	15	5.1	0.4	13.5
5	defect ¹	defect ¹	defect ¹	defect ¹

¹ Defect (the test sample was ruptured already at a load of 200 N, probably due to the occurrence of the defect).

Table 2 and Figure 10 show the test results. The variation of measured values is evident in both tensile strength and deformation work.

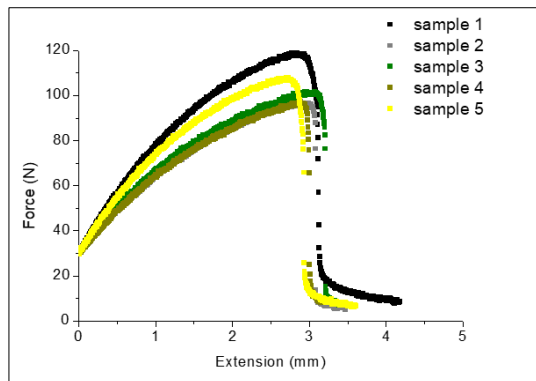

Figure 10. Three-point bending test average of ultimate bending strength 16.75 MPa, deformation work 0.91 mJ

Table 2. Results of three-point bending test.

Sample No.	Ultimate bending strength [MPa]	Deformation work [mJ]
1	18.76	1.01
2	15.69	0.92
3	16.71	0.90
4	15.44	0.80
5	17.13	0.92

4. Conclusions

Based on the destructive testing (tensile test and three-point bending test), we can conclude the followings:

- in terms of strength, the material gives comparable results both in three-point tensile load and bending,
- in terms of bending strain, the material gives a lower range of values in comparison to three-point load – this could be linked to an orientation of filling particles in the composite material,
- in both situations, deformation work is rather low – under certain conditions in practice, this could rise some problems,
- the described dependencies using equations (1) to (4) are very important for identification, subsequent optimization and prediction of physical-mechanical properties in relation to the technical parameters of the concerned material, and, in particular, to the knowledge of their technical exploitation.

Significant differences between the mechanical properties values recorded after the tensile test, and three-point bending test resulted from non-homogeneity of the material – flawed encapsulation of wooden particles by the plastic and the occurrence of cracks in the contact area between the two components.

Acknowledgments: This work was supported by project KEGA 030TUKE-4/2018 (Popularization and transfer the strategy Industry 4.0 into the technical study programs focusing on secondary schools).



References

1. KLESOV, A. A. *Wood-plastic composites*. Hoboken, N.J.: Wiley-Interscience, 2007.
2. The Giant's Kettle at World Expo, Shanghai, China | UPM ProFi. Composite decking - designed to be better | UPM ProFi [online].
3. CLEMONS, C. M. Wood-plastic composites in the United States: The interfacing of two industries, *Forest Prod. J.*, **52**(6), 2002, 10 – 18.
4. WESCHLER, A., HIZOROGLU, S. Some of the properties of wood–plastic composites, *Build Environ.*, **42**(7), 2007, 2637- 2644.
5. MALDAS, D., KOKTA, B. V., DANEALUT, C., Influence of coupling agents and treatments on the mechanical properties of cellulose fiber–polystyrene composites, *J Appl. Polym. Sci.*, **38**(3), 1989, 751-775.
6. STARK, N. M., ROWLANDS, R. E., Effects of wood fiber characteristics on mechanical properties of wood/polypropylene composites, *Wood Fibre Sci.*, **35**(2), 2003, 167-174.
7. BOUAFIF, H., KOUBAA, A., Effects of Fiber Characteristics on the Physical and Mechanical Properties of Wood Plastic Composites, *Compos. Part A-Appl. S.*, **40**(12), 2009, 1975-1981.
8. ADHIKARY, K. B., PANG, S., STAIGER, M. P., Dimensional stability and mechanical behaviour of wood-plastic composites based on recycled and virgin high-density polyethylene (HDPE), *Compos. Part B-Eng.*, **39**(5), 2007, 807-815.
9. CHEN, H. C., CHEN, T. Y., HSU, C. H., Effects of wood particle size and mixing ratios of HDPE on the properties of the composites, *Eur. J. Wood Prod.*, **64**(3), 2006, p. 172-177.
10. VINAYAGAMOORTHY, R., Influence of fiber surface modifications on the mechanical behavior of *Vetiveria zizanioides* reinforced polymer composites, *J. Nat. Fibres*, **16**(2), 2019, 163 -174.
11. FAKIROV, S., BHATTACHARYYA, D.: *Handbook of engineering biopolymers: homopolymers, blends and composites*, Hanser Verlag, Munich, 2007.
- 12.*** Engineering properties of wood-plastic composite panels. MINDS@UW Home [online]. Available from: <https://minds.wisconsin.edu/handle/1793/6577>.
13. MIGNEAULT, S., KOUBAA, A., ERCHIQUI, F., CHAALA, A., ENGLUND, K., WOLCOTT, M. P., Effects of processing method and fiber size on the structure and properties of wood–plastic composites, *Compos. Part A-Appl. S.*, **40**(1), 2009, 80-85.
14. KHAN, M. A., ALI, K. I. J., Studies of physico–mechanical properties of wood and wood plastic composite (WPC), *Appl. Polym. Sci.*, **45**(1), 1992, 167 – 172.
15. CHAHARMAHALI, M., MIRBAGHERI, J., TAJVIDI, M., NAJAFI, S. K., MIRBAGHERI, Y., Mechanical and physical properties of wood-plastic composite panels, *J. Reinf. Plast. Comp.* **29**(2), 2010, 310 – 319.
16. TAKATANI, M., OKAMOTO, T., Wood/plastic composite of high filler content, *Mol. Cryst. Liq. Cryst.*, **483**(1), 2008, 326 – 338.
17. PRITCHARD, G. *Plastics, Additives and Compounding*, **6** nr.4, 2004, p. 18.
18. SOURY, E., BEHRAVESH, A. H., ESFAHANI, E. R., ZOLFAGHARI, A., Design, optimization and manufacturing of wood–plastic composite pallet, *Mater. Des.*, **30**(10), 2009, 4183 – 4191.
19. KHAN, M. A., ALI, K. I., JAHAN, M. S., Characterization of wood and wood-plastic composite, *Polym Plast Technol Eng.*, **38**(4), 1999, 753 – 765.
20. HUTYROVÁ, Z., ŠČUČKA, J., HLOCH, S., HLAVÁČEK, P., ZELENÁK, M., Turning of wood plastic composites by water jet and abrasive water jet, *Int. J. Adv. Manuf. Tech.*, **40**(5-8), 2015, 1615 – 1623.
21. HUTYROVA, Z., HARNICAROVA, M., VALICEK, J., KUSNEROVA, M., ZAJAC, J. Statistical evaluation of impact of technological factors on surface texture of WPC composites, *Mater. Plast.*, **52**(3), 2015, 325-329.

Manuscript received: 15.11.2019